



Less able damage resistant  
anti-ligature WC pan

### Applications

Suitable for installation within custodial, healthcare and commercial environments.

### Features

- ~ Damage resistant
- ~ Anti-ligature
- ~ Range of activation and control options available
- ~ Raised height for less able applications
- ~ EN outlet connection.



### Dimensional Data

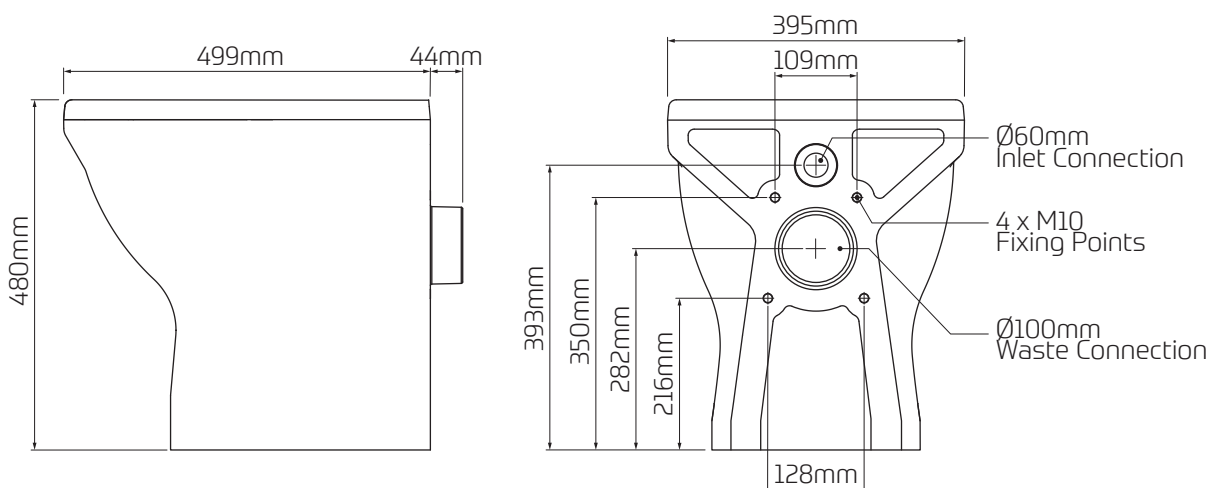

### Technical Data

Material	Polymer Resin
Available Finishes	Matt, Gloss
Product Weight	52 kg
Fixing Orientation	Wall Fixed
Fixing Size	M10
Standard Conformity	BS 476 Pt.6 Fire propagation & surface spread of flame. ISO EN 19712-3-2007 Rated 5 for durability, stain resistance, cigarette burns etc.