



General Enquiries: 0121 557 5411
Sales: 0121 530 7000



0121 557 5345



sales@thomasdudley.co.uk



www.thomasdudley.co.uk



Thomas Dudley Ltd
P.O.Box 28
Birmingham New Road
Dudley
West Midlands
DY1 4SN

Remora

Pneumatic Stainless Steel Flushplate Instructions



1 PACK CONTENTS

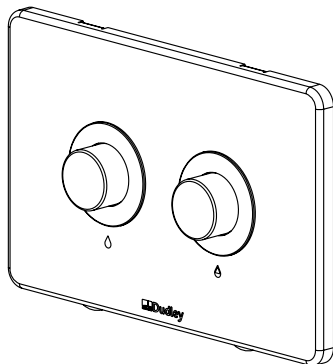

Push Plate

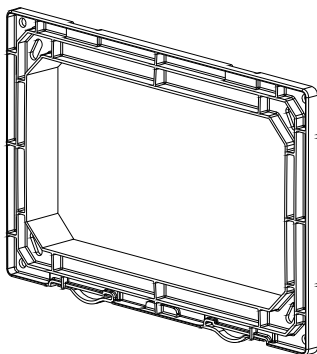

Cover Mount

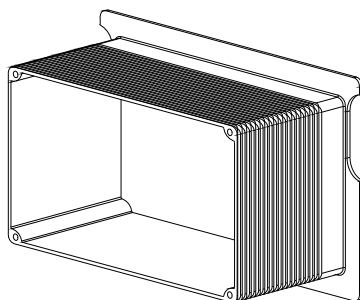

Tunnel



Screws x 4

4 INSTALLATION INSTRUCTIONS continued

Step 5

Position the flush plate on the lower edge of the mounting frame engaging with the spring clip features.

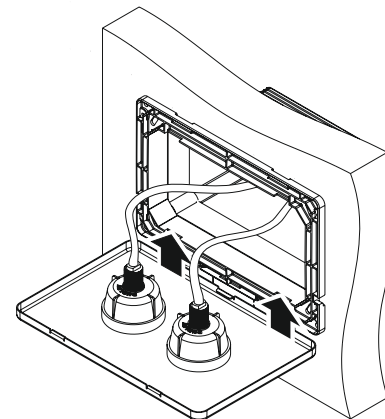

Step 6

Lift and rotate the flush plate around the lower edge until the top edge of the push plate snaps over the top edge of the mounting frame.

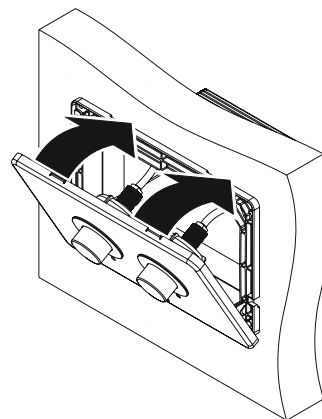

Fully installed.

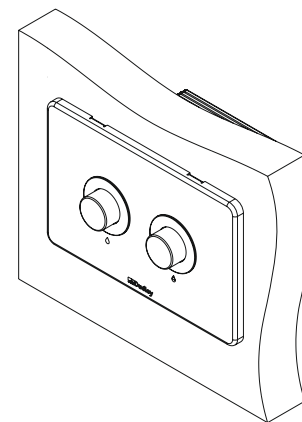

5 CLEANING AND MAINTENANCE INSTRUCTIONS



WARNING !

DO NOT USE ANY CLEANING AGENTS ON THIS PRODUCT.
USE A NON ABRASIVE CLOTH AND WARM WATER.

4 INSTALLATION INSTRUCTIONS Continued

Step 3 - To be carried out if service cover is removed

Remove existing pneumatic tubes from the Niagara outlet valve making note of the configuration. Connect supplied 750mm pneumatic tubes to Niagara valve ensuring the tubes are fully engaged on nipple.

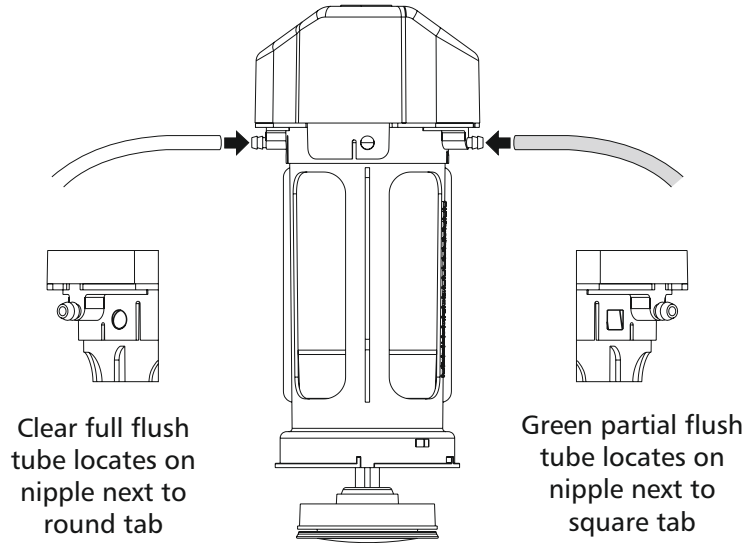

Step 4

Connect the pneumatic tubes to the outlet nipples on the flush plate. The tubes should be cut to a minimum working length. Avoid kinks.

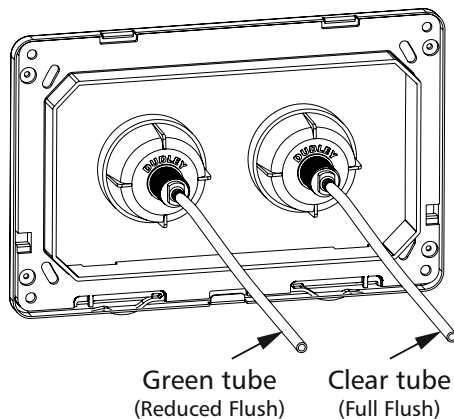

2 INSTALLATION OPTIONS

Option 1

Behind partition with cistern fixed to back wall.

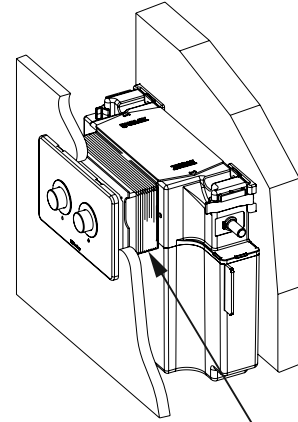

Option 2

Behind partition with Dudley Illusion Frame.

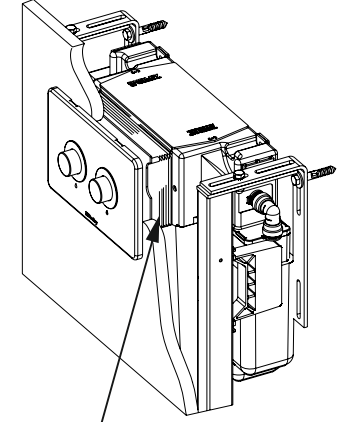

Tunnel used to bridge gap between partition and cistern service aperture.

Option 3

Top access

Note: Longer fixing screws required.

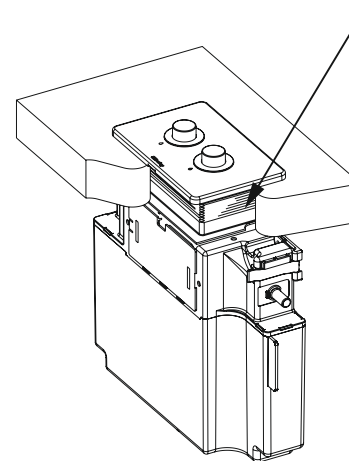

Option 3

Remove top service cover before installation

Option 1 & 2

Remove front service cover and detach standard pneumatic tubes before installation

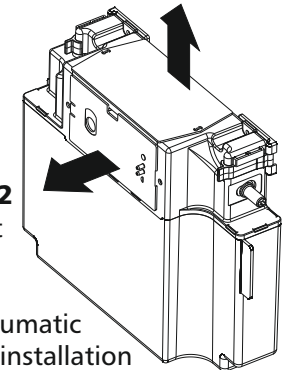

3 INSTALLATION DIMENSIONS

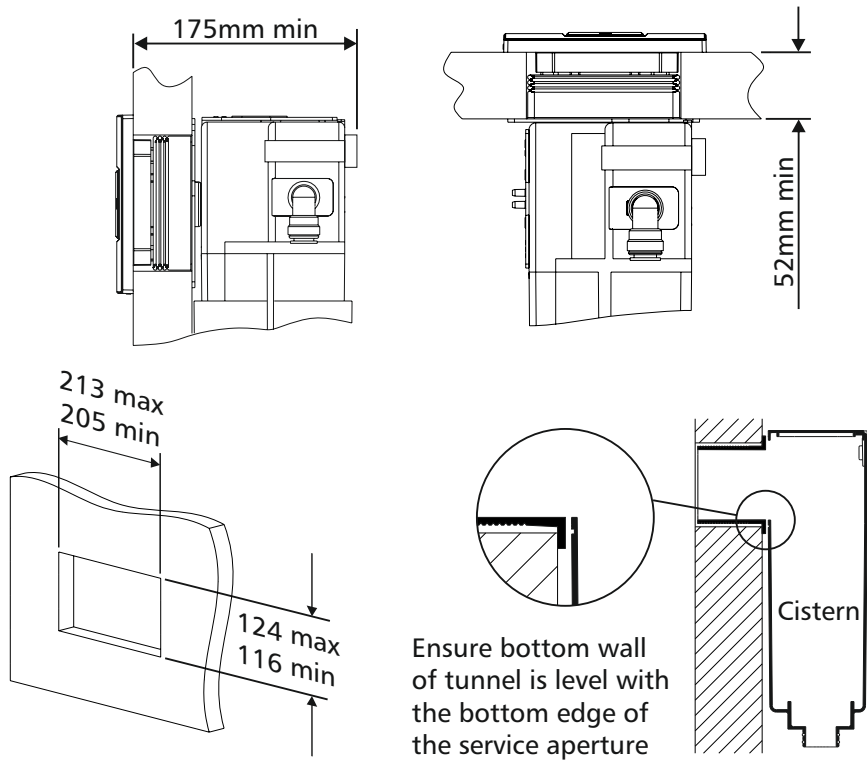

4 INSTALLATION INSTRUCTIONS

Step 1
Cut tunnel to required depth.

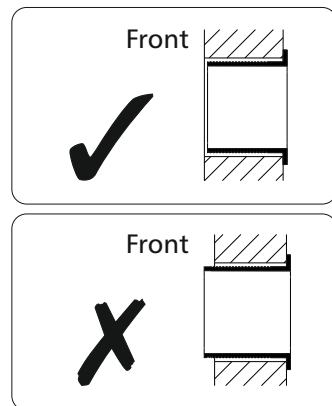
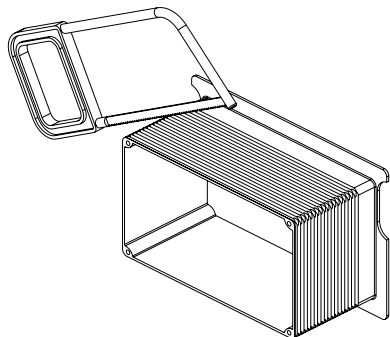

4 INSTALLATION INSTRUCTIONS Continued

Step 2
Position tunnel and attach cover mount using the 4 screws provided. Tighten until clamped in position.

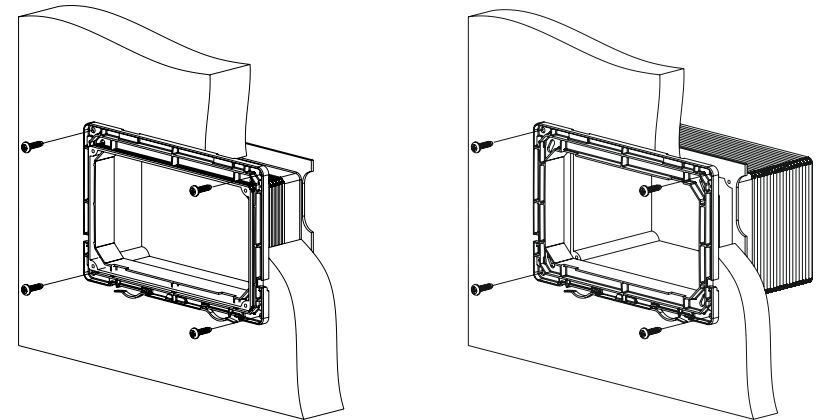

Note
When the tunnel is used in applications shown below longer fixing screws may be required (not supplied).

