

Slimline & Mirage

CISTERN INSTALLATION INSTRUCTIONS

Dudley cisterns are designed to be fixed flat to the wall with suitable rust resistant screws (not supplied) using the holes provided. Cisterns can be fitted for right or left hand operation.

WARNING

No sealing compound, paste, flux, silicone or solvent to be used in contact with plastic or rubber surfaces, to avoid damage to plastic components. Rubber washers should provide adequate seal. PTFE tape may be used on threads. Do not overtighten plastic nuts. No chemical block/additive to be used in this cistern.

Before fixing the cistern to the wall, it is advisable to fit the cisterns internal components...

1 INSTALLATION INSTRUCTIONS

The cistern is factory set to give a full flush of 6 litres (4 litres in some specifications). 6 litre cisterns are capable of being set up to deliver a 6 or 7 litre full flush. (**Fig. 1**).

Syphon Installation

Install the syphon with its rubber sealing washer inside cistern. Secure with 1½" BSP back nut. Before fixing the cistern to the wall, it is advisable to fit the remainder of all internal components. Insert flush bend into tail of syphon with the cap nut & rubber compression ring in place. Hand tighten the cap nut. Depending on the height of the cistern from the floor, it may be necessary to cut the flush pipe. Remove traces of burr. No more than 50mm (2") of flush pipe to be inserted into the syphon down leg. (**Fig. 2**).

Important: 6 litre flushing is the maximum permissible flush for new WC installations. 4 litre flushing should only be used for WC pans specifically designed for that purpose. To convert syphons from a dual flush to a single mono flush please see separate instructions (11359 - Conversion to Single Flush for Dudley WC Syphons). Flush volumes above 6L should only be used when retrofitting to older WC installations.

Ball Float Valves

Bottom and side entry types are fitted with 3mm (1/8") bore high pressure seats (white) to suite mains water supply. A low pressure 6mm (1/4") bore seat (red) is also provided for use only when the cistern is fed from a low pressure supply i.e. a storage tank. Screw ball float onto the end of the arm before fitting valve. Set float position after fitting in to cistern if it is fitted with a swivel arm. (**Fig. 3**).

Side Entry

Screw a spigot nut onto the tail with spigot side facing inwards. Locate the valve tail through the cistern wall. Tighten the second spigot nut with spigot facing towards the cistern to centralise valve in hole. (**Fig. 4**).

Pedestal Bottom Entry

Locate the pedestal float valve tail through the base of the cistern with rubber sealing washer on the inside. Secure using spigot nut facing inwards to locate the pedestal centrally in the cistern hole. Position pedestal to ensure free movement of the float arm. Trim the bracing stay so that it touches the cistern wall and tighten spigot nut. (**Fig. 4**).

Important: Make certain that the float arm moves freely in a vertical path and does not contact other internal components. Position the overhead discharge elbow (**Fig. 3**) so that it is not directed into the reservoir of the syphon. (**Fig. 3**).

Equilibrium Inlet Valves

Follow the instructions supplied with the inlet valve.

Water Level

Adjust the inlet valve float arm with the adjusting screw and lock nut or the float on the equilibrium inlet valves. So that the valve shuts off at the required marked water line. Re-check and adjust if necessary. (**Fig. 4**).

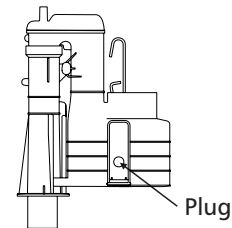

Flush	Water Line	Plug
4 Litre	7/6/4L	4L (Plug Out)
6 Litre	7/6/4L	6L (Plug Out)
6 Litre	7/6/4L	7L (Plug In)

Fig 1

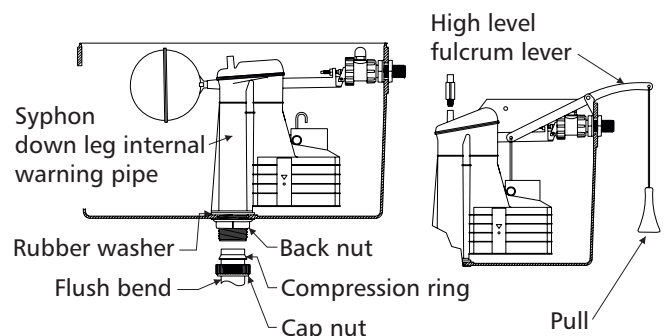

Fig 2

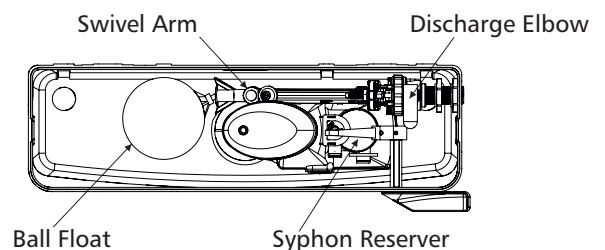

Fig 3

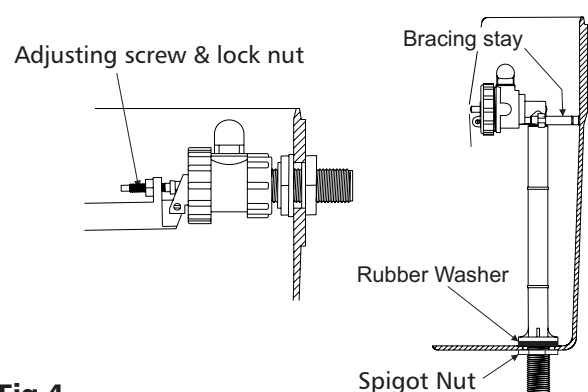

Fig 4

1 INSTALLATION INSTRUCTIONS - CONTINUED

Blanking Plugs

Fit a blanking plug to seal off the unused cistern inlet holes. Press badge or plug into unused lever holes. (Fig. 5).

Overflow Warning

The cistern is supplied with an internal overflow warning that discharges directly into the WC pan. (Fig. 2).

Lever Assembly

Install the operating lever through the cistern lever hole. Secure the lever with back nut. Connect 'C' link to the lift arm, then slide the lift arm onto the square lever shaft and tighten the securing screw. Ensure that the lift arm is in line with the 'C' link and syphon piston rod. Check for correct operation of the lever assembly. (Fig. 6).

High Level Cisterns Only

Attach the fulcrum lever to the 'C' link. Fit the fulcrum lever bracket into the cistern dovetail slot. Secure with screw and nut supplied, then attach the lever pull (Fig. 2). To accommodate the fulcrum lever, cut a slot in the thin section at the end of the cistern lid.

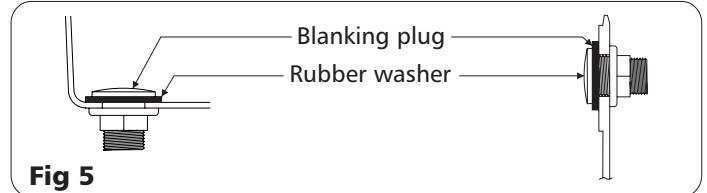

Fig 5

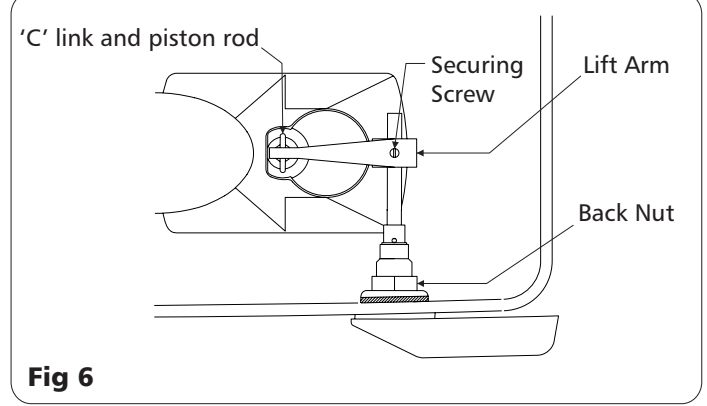

Fig 6

2 FITTING THE SLIMLINE CISTERN LID

Fitting the Lid

It is essential that the lid is securely fitted to the cistern with the screws provided. Attach the lidfix extension(s) where provided and secure one or two extensions to the syphon cap. Fit the lid and secure the lidfix screw through the cistern lid into the extension piece(s).

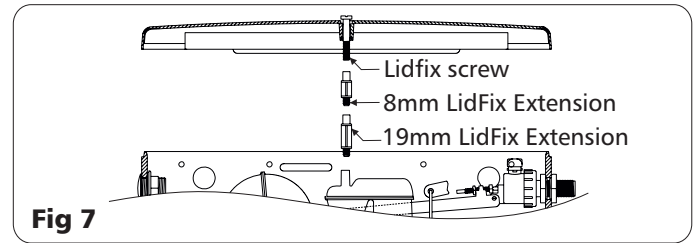

Fig 7

3 FINAL CHECK LIST

Before turning on water supply check the following:

- ① CISTERN IS SECURE
- ② ALL MOVING COMPONENTS OPERATE FREELY
- ③ ALL JOINTS ARE TIGHTENED CORRECTLY

Now fill the cistern, set the water level and check the following:

- ④ CHECK CAREFULLY FOR LEAKS
- ⑤ ENSURE ALL MOVING COMPONENTS OPERATE FREELY
- ⑥ CHECK FLOAT ARM MOVES FREELY UP & DOWN AND CLOSES OFF CORRECTLY
- ⑦ TEST THE SYPHON OPERATION AND THAT THE CISTERN FLUSHES CORRECTLY

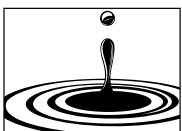

Dudley
Water saving solutions

Thomas Dudley Ltd
P.O.Box 28, Birmingham New Road, Dudley, West Midlands, DY1 4SN

Telephone: 0121 557 5411 E-mail: sales@thomasdudley.co.uk

© 2019 Thomas Dudley Ltd | R334041 14187 iss D